

Drop-In
Drop-in refrigerated stainless steel
surface (2 GN container capacity) with A
overshelf

ITEM # _____

MODEL # _____

NAME # _____

SIS # _____

AIA # _____

341171 (D14C20)

Drop-in Refrigerated stainless steel Surface (2 GN container capacity) with one A type overshelf and LED light

Short Form Specification

Item No. _____

Hydrocarbon refrigerant gas R290 for the lowest environmental impact (GWP=3) - CFC and HCFC free. Well in 304 AISI stainless steel with rounded corners to facilitate cleaning operations. The well is also equipped with a drain hole. Automatic defrosting guarantees evaporators clearance and efficient well cooling. High-density expanded polyurethane foam with cyclopentane guarantees excellent well insulation to reduce energy dispersion. The bottom is equipped with copper tubes to ensure proper cooling, with this system the air touches the cold surface and gets cooled. Pressed Stainless steel top 30mm deep with rounded edges and drain hole for easier cleaning. Stylish A type overshelf designed for extra increased visibility on the surface for charming food display. Overshelf equipped with LED lights.

Main Features

- CB and CE certified by a third party notified body.
- Precise temperature control and setting at 0,1°C .
- As standard the product comes with digitally controlled thermostat which is in line of HACCP norms and provides visual alarm as a warning of the increasing or decreasing temperatures.
- Food introduced at the correct temperature maintains its core temperature according to Afnor Standards.
- Automatic defrosting guarantees evaporators clearance and efficient well cooling.
- Designed to serve the food on plates .
- Equipped with a drain hole to easily discharge top condensation.
- Stylish A type overshelf designed for extra increased visibility on the surface for charming food display.
- Overshelf equipped with LED lights.
- Designed to be positioned in flush installation providing improved cleanability and suitable for modern design installations.

Construction

- Well bottom is inclined to facilitate water drainage.
- Well in 304 AISI stainless steel with rounded corners to facilitate cleaning operations. The well is also equipped with a drain hole.
- Electronic control with temperature display.
- IPx2 water protection.
- The bottom is equipped with copper tubes to ensure proper cooling, with this system the air touches the cold surface and gets cooled.
- Pressed Stainless steel top 30mm deep with rounded edges and drain hole for easier cleaning.
- Overshelf in complete AISI 304.

Sustainability



- Hydrocarbon refrigerant gas R290 for the lowest environmental impact (GWP=3) - CFC and HCFC free.
- High-density expanded polyurethane

APPROVAL: _____

foam with cyclopentane guarantees excellent well insulation to reduce energy dispersion.

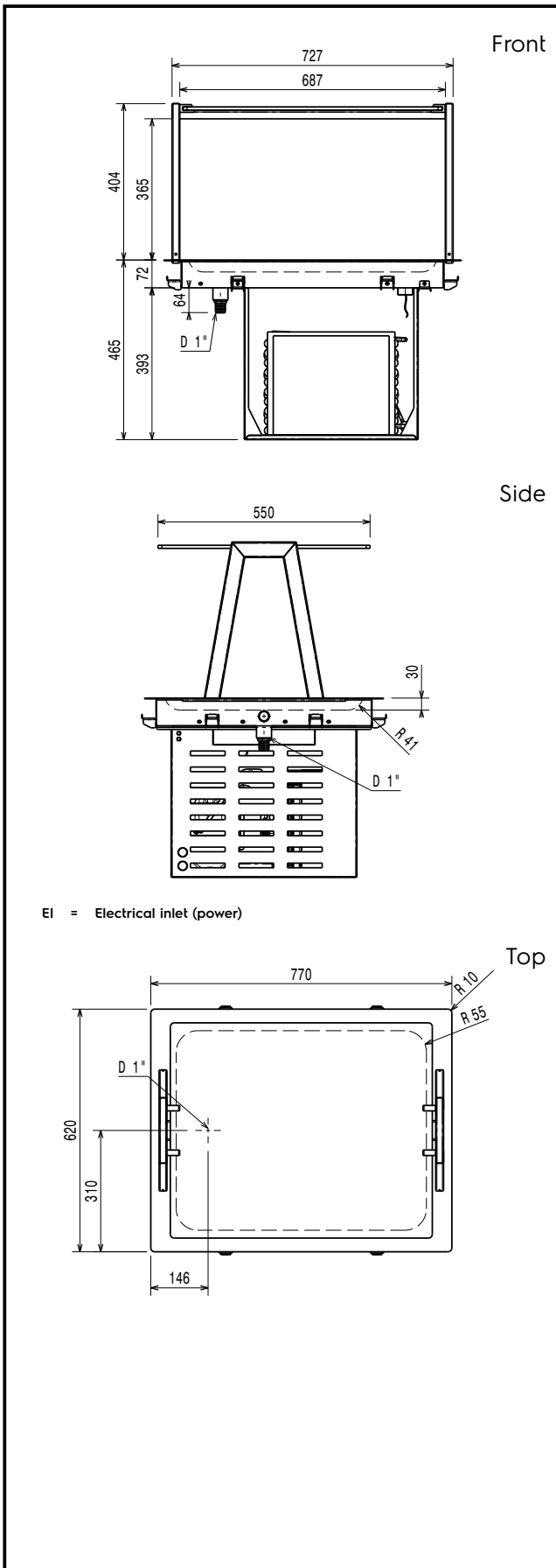

Electric

Supply voltage:

341171 (D14C2O) 220-240 V/1N ph/50 Hz

Electrical power max.:

0.47 kW

Water:

Water drain outlet size:

Key Information:

External dimensions, Width:	770 mm
External dimensions, Depth:	620 mm
External dimensions, Height:	794 mm
Net weight:	50.76 kg
Shipping weight:	74 kg
Shipping height:	1060 mm
Shipping width:	660 mm
Shipping depth:	810 mm
Shipping volume:	0.57 m ³
Set temperature:	-10 / 0 °C
Top temperature:	-10 / 0 °C

Refrigeration Data

Refrigerant type: R290

Sustainability

Noise level: 58,8 dBA

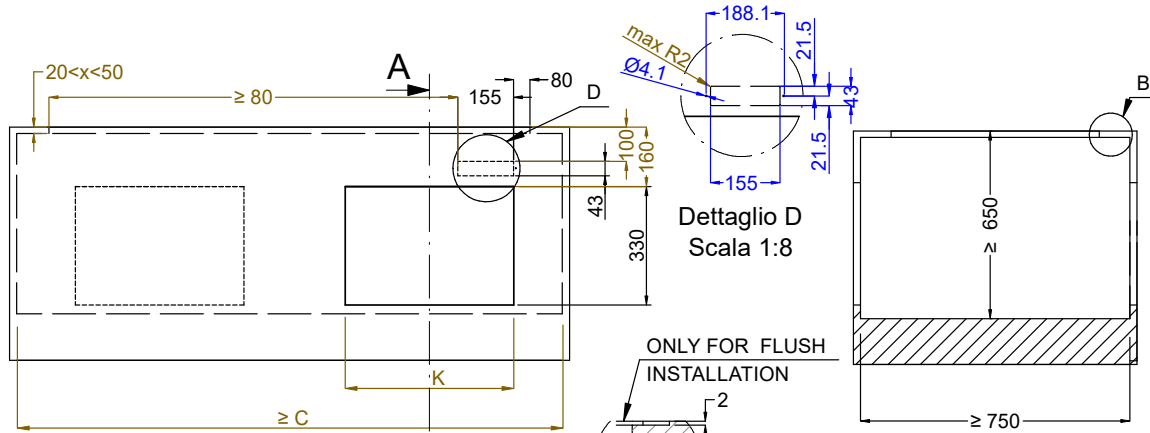

Front view
Scala: 1:20

Section Cut A-A
Scala: 1:20

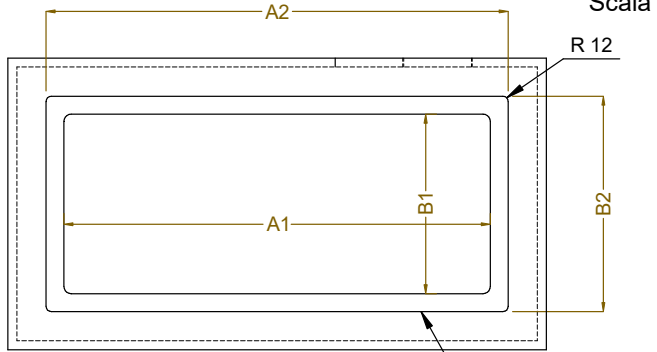

Top view
Scala: 1:20

CAPACITY	CUTOUT		LOWERING FOR FLUSH INSTALLATION		C	K
	A1	B1	A2	B2		
2GN	740	580	774	624	870	470
3GN	1070		1104		1200	
4GN	1390		1424		1520	

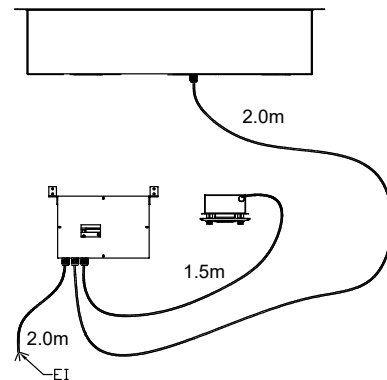
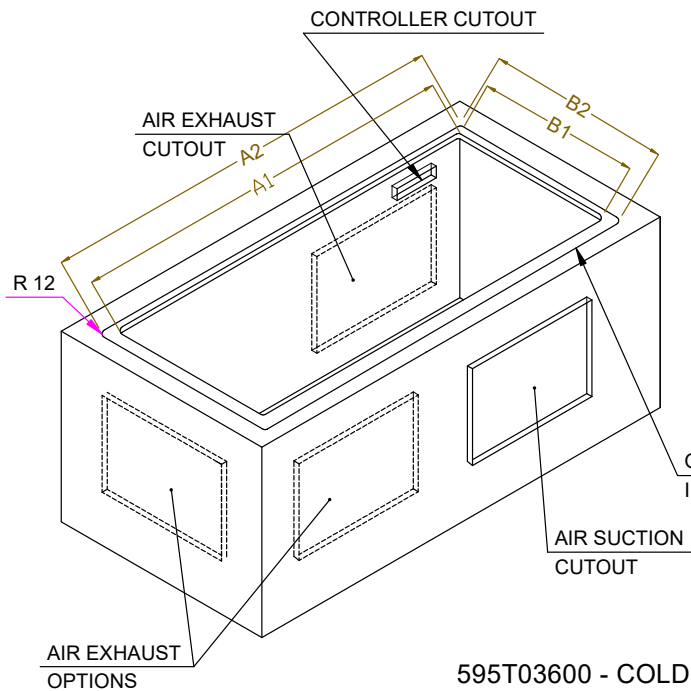

595T03600 - COLD S/S SURFACE OVERSH. ON THE FRAME

AIR EXHAUST
OPTIONS